

Varde Als Varde Birkholm Varde Falster Varde Lolland Varde Samsø Varde Tunø

Installation— and User guide

Revision 5

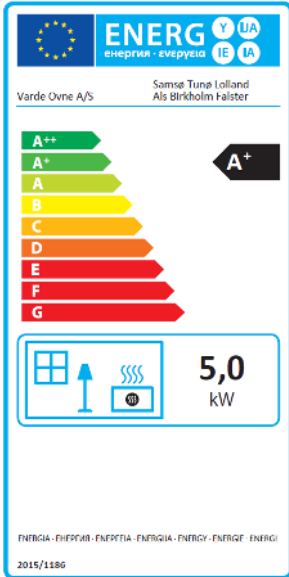

Pottemagervej 1, 7100 Vejle, Danmark. WWW.vardeovne.dk

Congratulations with the purchase of your new wood-burning stove

Wood-burning stoves from VARDE stand on the stylistic bedrock of Scandinavian design – created with the ambition of unifying quality, functionality and design.

With a VARDE stove, you and your family are ensured a warm gathering point and tranquil quality moments for many years into the future.



Henrik Nøhr
CEO
Varde Ovne A/S

Index

Welcome and index	Page 2
Technical specifications Als	Page 3
Technical specifications Birkholm	Page 4
Technical specifications Falster	Page 5
Technical specifications Lolland	Page 6
Technical specifications Samsø	Page 7
Technical specifications Tunø	Page 8
Regulations and approval	Page 9
Flooring and distance	Page 10
Installation distances	Page 11
Chimney	Page 12
Connecting the chimney	Page 13
Air supply	Page 14
How it works	Page 15
How to light and stoke a fire	Page 16
Operation	Page 17
Vermiculite	Page 18
How to choose wood	Page 19
Maintenance	Page 20
Troubleshooting	Page 21
Spare parts	Page 22
Test certificate	Page 23
Test certificate	Page 24
Warranty	Page 25

Technical Specification Als

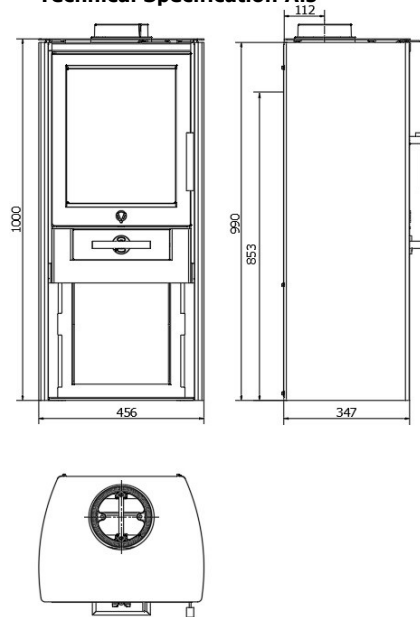

Model Als

Height (mm)	1000
Wide (mm)	456
Depth (mm)	349
Weight (kg)	80
Effect	3-7 kW
Nominal Output	5,0 kW
Heated area	30-105m ²
Efficient	81%
EEl	108
Flue gas data	295°C at 20°C, 11Pa.

Combustion Chamber : (H x B x T):
260/380 x 200/300 x 300mm

Flue outlet Ø15cm:
Mounting height top: 99cm
Mounting height rear - center 85cm

Distance to non inflammable:
5-10cm (Recommended)

Distance to inflammable wall and material:
Rear = 20cm, Sides = 20cm, In front = 80cm



Technical Specification Birkholm

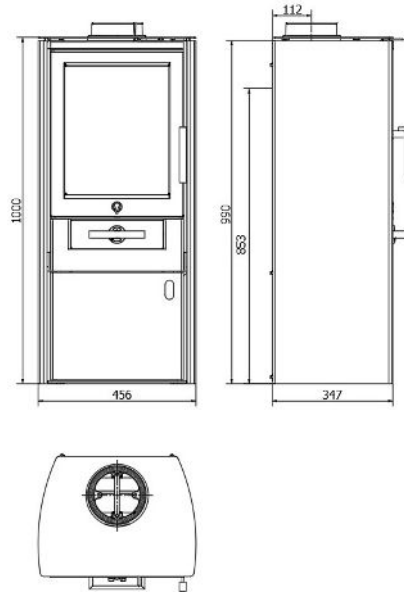

Model Birkholm

Height (mm)	1000
Wide (mm)	456
Depth (mm)	349
Weight (kg)	80
Effect	3-7 kW
Nominal Output	5,0 kW
Heated area	30-105m ²
Efficient	81%
EEI	108
Flue gas data	295°C at 20°C, 11Pa.

Combustion Chamber : (H x B x T):
260/380 x 200/300 x 300mm

Flue outlet Ø15cm:

Mounting height top: 99cm

Mounting height rear - center 85cm

Distance to non inflammable:

5-10cm (Recommended)

Distance to inflammable wall and material:

Rear = 20cm, Sides = 20cm, In front = 80cm

Technical Specification Falster

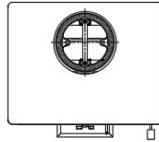
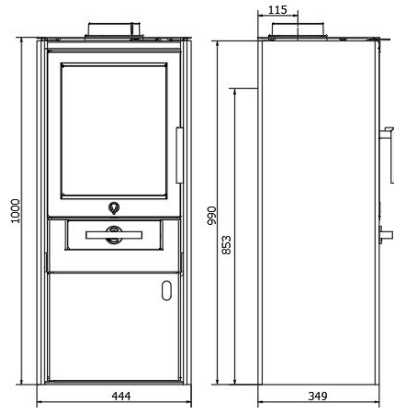

Model Falster

Height (mm)	1000
Wide (mm)	444
Depth (mm)	349
Weight (kg)	80
Effect	3-7 kW
Nominal Output	5,0 kW
Heated area	30-105m ²
Efficient	81%
EEl	108
Flue gas data	295°C at 20°C, 11Pa.

Combustion Chamber : (H x B x T):
260/380 x 200/300 x 300mm

Flue outlet Ø15cm:
Mounting height top: 99cm
Mounting height rear - center 85cm

Distance to non inflammable:
5-10cm (Recommended)

Distance to inflammable wall and material:
Rear = 20cm, Sides = 20cm, In front = 80cm

Technical Specification Lolland

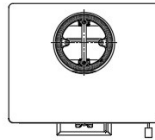
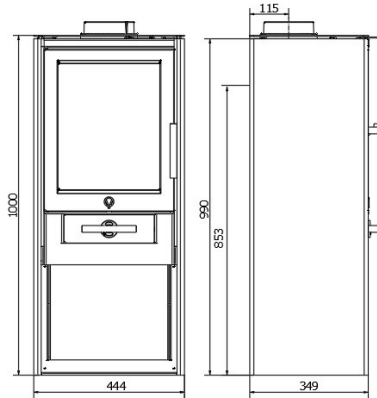

Model Lolland

Height (mm)	1000
Wide (mm)	444
Depth (mm)	349
Weight (kg)	80
Effect	3-7 kW
Nominal Output	5,0 kW
Heated area	30-105m ²
Efficient	81%
EEl	108
Flue gas data	295°C at 20°C, 11Pa.

Combustion Chamber : (H x B x T):
260/380 x 200/300 x 300mm

Flue outlet Ø15cm:
Mounting height top: 99cm
Mounting height rear - center 85cm

Distance to non inflammable:
5-10cm (Recommended)

Distance to inflammable wall and material:
Rear = 20cm, Sides = 20cm, In front = 80cm

Technical Specification Samsø

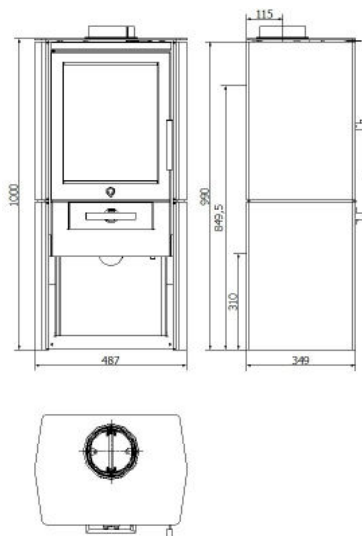

Model Samsø

Height (mm)	1000
Wide (mm)	487
Depth (mm)	349
Weight (kg)	80
Effect	3-7 kW
Nominal Output	5,0 kW
Heated area	30-105m ²
Efficient	81%
EEl	108
Flue gas data	295°C at 20°C, 11Pa.

Combustion Chamber : (H x B x T):
260/380 x 200/300 x 300mm

Flue outlet Ø15cm:

Mounting height top: 99cm

Mounting height rear - center 85cm

Distance to non inflammable:

5-10cm (Recommended)

Distance to inflammable wall and material:

Rear = 20cm, Sides = 20cm, In front = 80cm

Technical Specification Tunø

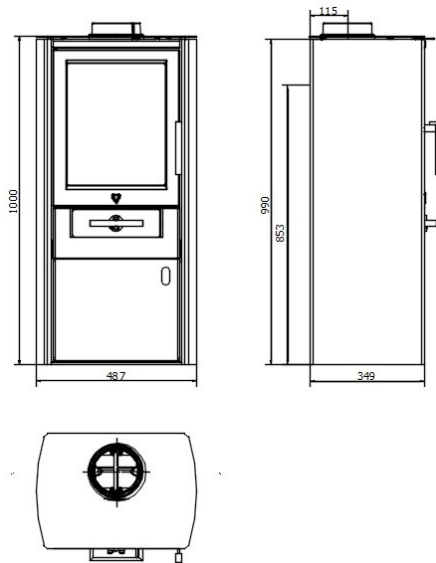

Model Tunø

Height (mm)	1000
Wide (mm)	487
Depth (mm)	349
Weight (kg)	80
Effect	3-7 kW
Nominal Output	5,0 kW
Heated area	30-105m ²
Efficient	81%
EEl	108
Flue gas data	295°C at 20°C, 11Pa.

Combustion Chamber : (H x B x T):
260/380 x 200/300 x 300mm

Flue outlet Ø15cm:
Mounting height top: 99cm
Mounting height rear - center 85cm

Distance to non inflammable:
5-10cm (Recommended)

Distance to inflammable wall and material:
Rear = 20cm, Sides = 20cm, In front = 80cm

Important!

Before igniting your **Varde Stove** for the first time, we recommend that you read these instructions carefully and contact your local stove vendor or building authorities to inquire about existing regulations regarding the installation of stoves. Please follow these regulations closely.

Inspection of installation

It is very important that the installation is inspected by a qualified chimney sweeper before the stove is used the first time.

This **Varde stove** is approved in accordance with: European Standard DS/EN 13240/PrEN 16510 German Stufe 2 and Norwegian NS and §15 for Austria and is accordingly certified as having eco-friendly combustion properties.

The stoves are designed for intermittent combustion and are also designed for chimneys with several stoves connected.

Please Note!

You are by law required to register your stove at the local chimney-sweeper.

Until installation keep the stove dry and not to cold. The stove cannot stand moisture. If using an existing chimney, it not necessarily effective enough for a new modern stove. Vermiculite is a very porous material, therefore handle with care. When refilling the stove, put the wood carefully, use the glove.

Regulations

The installation must comply with all local regulations, including those that refer to national and European standards. Seek advice and guidance from the dealer from which you bought the stove or from a professional installation technician.

NB: All Varde wood-burning stoves are closed fires.

Professional installation

We recommend that you seek advice from the dealer you purchased the stove from or from another competent installation technician, as there can be specific details that must be taken into consideration with the installation.

EC declaration of confirmaty.

MANUFACTURER

Name:
Adress

Varde Ovne A/S
Pottemagervej 1, DK-7100 Vejle, Denmark

Stove Inspection

Name:
Adress

RRF
Im Lopperfeld 34b, 46047 Oberhausen, Germany

Product

Product type
Type code
Standard

Varde
Als, Birkholm, Falster, Lolland, Samsø, Tunø
Heating stove, suitable for intermittent combustion
Costruction products (89/106/EC/) standard used
EN 13240

Application
Fuel
Special conditions

Residential Heating
Wood
Non

CE-Markning

Issued
Nominal Output
Fuel type
Fluegas temperature
Efficiency
Co-release

2015 / 2017
5,0 kW
Wood
295 °C
81 %
0,09 %



Henrik Nøhr
CEO
Varde Ovne

Flooring:

If the floor on which the stove is to be placed is inflammable, the floor must be covered with non-flammable material, such as steel or glass plate, floor tiles or artificial slate, covering an area of at least 15 cm from the sides of the stove and at least 30 cm from the front of it. Regarding the front, however, we recommend 50 cm. Also, the Floor construction must be capable of carrying

Weight	Steel Stove
Varde Als, Birkholm, Falster, Lolland, Samsø og Tunø	80 kg

Installation distance:

If walls are non-inflammable, the stove can be placed closer to them. However, we recommend a minimum distance of 5-10 cm, to allow for cleaning behind the stove. The cleanout gate must be accessible. Optimal combustion can only be obtained if fresh air is constantly admitted. It is important, therefore, to ensure that this is the case. The best way to provide a steady flow of fresh air is by installing 1-2 air vent's in the room where the stove is situated. (One in each side of the room).

Installing the stove in relation to combustible material.

It is recommended that there is a distance of 22,5 cm from the outer edge of the flue to any combustible material. Please note that there may be other national and local regulations relating to the distance to combustible material. Contact your local chimney inspector for advice.

Installation distance

The stove must in accordance with applicable rules comply with the following minimum distances from inflammable walls and materials:

Sides : 20 cm

Rear : 20 cm

Distance to furniture : 80 cm

NB: Note that B (from chimney to wall) is a recommendation. There may be different local/national rules.

Varde Als, Birkholm, Falster, Lolland, Samsø und Tunø

A	200 mm	C	200 mm
B	225mm	D	800 mm

Als and Birkholm

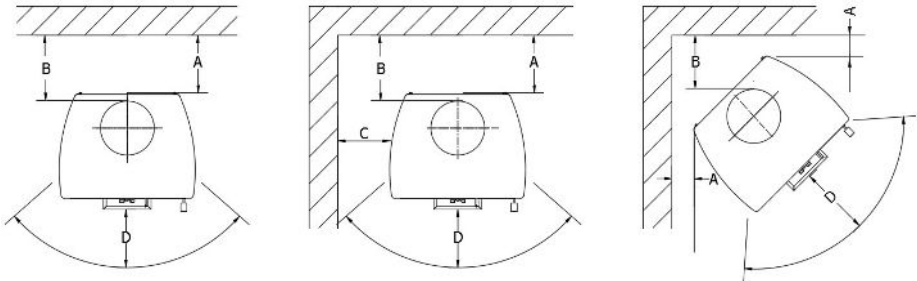

Falster and Lolland

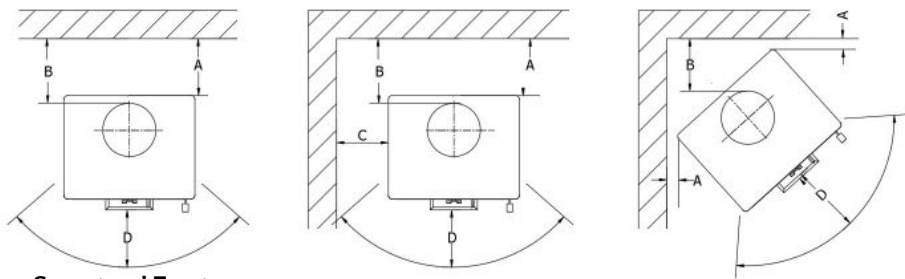

Samsø and Tunø

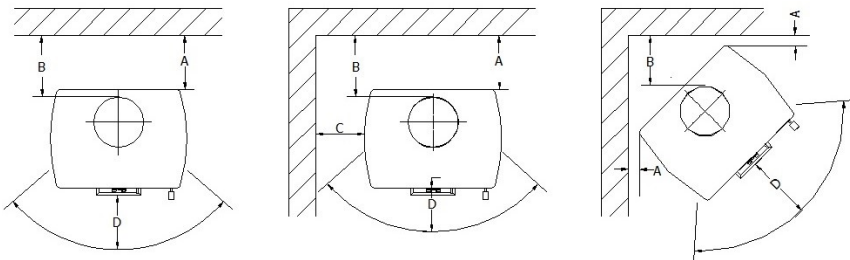

Chimney:

There must always be a chimney stack with a diameter of at least 15 cm. This is equivalent to clearing of 175 cm². Remember to ensure that the **draught conditions** are satisfactory and that smoke does not inconvenience your neighbours.

If your chimney has a regulating damper, the draught can be regulated. Please note that the damper must never be completely closed. There must always be at least 20 cm² of free passage through the chimney.

In some cases, it can be an advantage on days when the wind is blowing strongly.

At nominal operation, the stove has been tested with a flue gas flow of 4,7 g/s and with flue gas temperature of 298°C at a room temperature of 24°C.

Varde stoves are always equipped with a smoke guide plate. This ensures that the smoke's path to the chimney is as long as possible. This ensures that the smoke's heat is released in your home rather than in the open air outside. The smoke guide plate lies loosely in the stove's combustion chamber and you must ensure that the plate is pushed all the way back against the combustion chamber's rear plate.

New chimney

If you shall install a new chimney, it is recommended to consult your local chimneysweeper, as there can be specific local circumstances that can have influence on the height or routing of the chimney. You can find inspiration, and common guideline on www.vardeovne.dk

Is my existing chimney good enough?

The chimney is the motor of the stove, the chimney is driven by heat, so it is important that you have a well function chimney in order for the stove to work properly.

A modern wood burning stove puts up higher demands for the chimney than older stoves. A modern stove burns both cleaner and more efficient than older stoves, the higher efficient will give more heat in your living room for the same amount of firewood. The higher efficiency of a modern stove also have that effect, that there are used less heat to generate draft your chimney.

It can be a possibility that your old chimney will not be able to build up a sufficient draft to run a modern clean burning stove, be course of the lesser heat lead into to the chimney.

This may occur with shorter or older brick chimneys, especially without an insulating core.

It is very rare that a steel chimney or modern insulated brick chimney not will be sufficient.

Typical effects of insufficient draft, smoke come out when door is opened and soot on the glass.

If you have a chimney with draft problems, a draft booster could be a solution.

It is recommended that you consult with your local chimneysweeper for more specific advice.

Condensation drain in the flue collar

Your stove is fitted with a cast iron flue collar from Varde Ovne. The flue collar is designed for a flue pipe (chimney) with an inner diameter of 150 mm.

You can establish a condensate drain yourself, if your steel chimney is to be fitted in the stove's top outlet:

Make a hole in the bottom of the exterior grate (at the mark) using a small chisel or similar, thus making the condensate drain yourself, if you need it.

Marking of condensation drain.

Make an opening using chisel or similar.

A condensate drain has now been made.

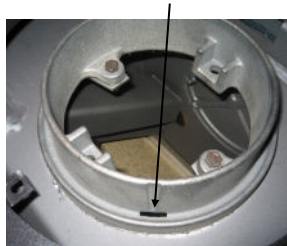

Connecting the flue pipe

Connect the stove using the top outlet.

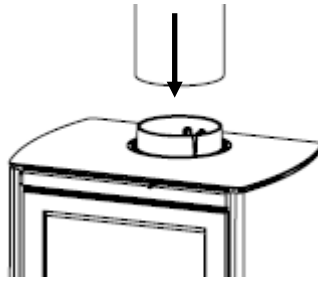

Connect the stove using the rear outlet.

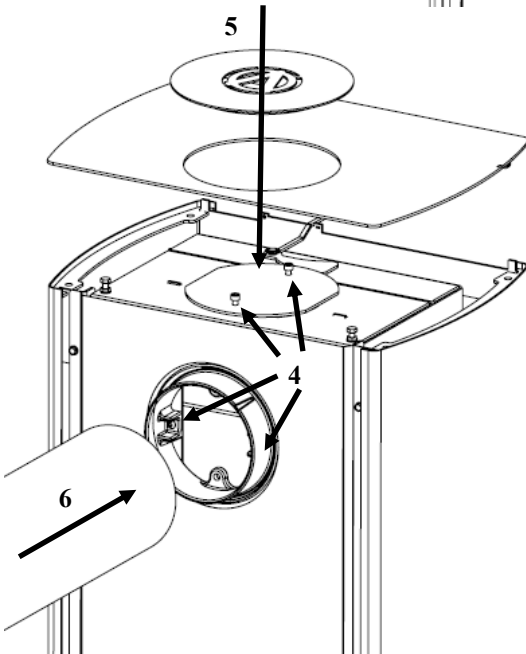
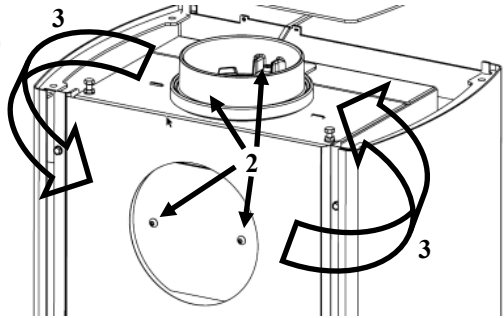
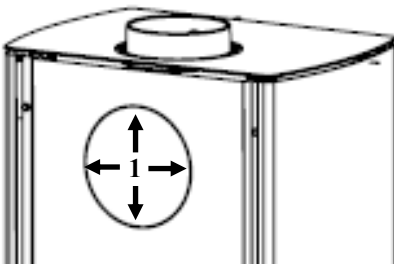

1. Cut the disc out in the back plate.
2. Unscrew the bolts in the flue collar and facing plate.
3. Swap the flue collar and facing plate.
4. Screw the bolts in the facing plate and flue collar.
5. Put the top plate into position.
NB! The cover plate to close the hole in the top plate is not supplied.
6. Fit the flue pipe

Continual fresh air

A continual supply of fresh air is required in the room in which the stove is situated. This can be achieved by installing 1-2 vents, whilst also ensuring that these can not be blocked. The quantity of air used for burning, is approx. 14 m³ / h.

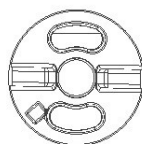

Ignition air
On Ashpan - **Open**

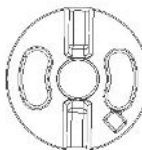

Optændingsluft
On Ashpan - **Closed**
This option is only for use at lightning up. As soon as the fire has a good grip-rememberber to close again.

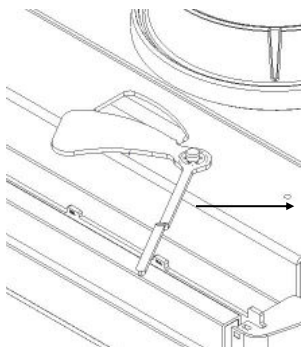

Combustion Air Throttlet
Push the Throttlet towards right for opening.

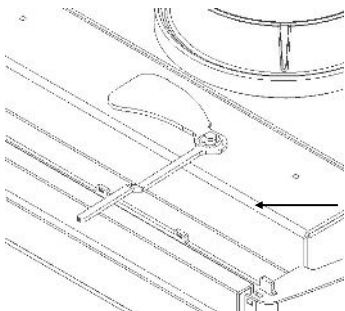

Combustion Air Throttlet
Push the Throttlet towards left for closing.

Combustion /Secondary air

Pre-heated air for the combustion process, the amount of which can be altered according to the desired room temperature and the effectiveness of the chimney. A high level of chimney draught requires a lesser intake of combustion air. Et højt skorstenstræk, kræver mindre tilførsel af forbrændingsluft

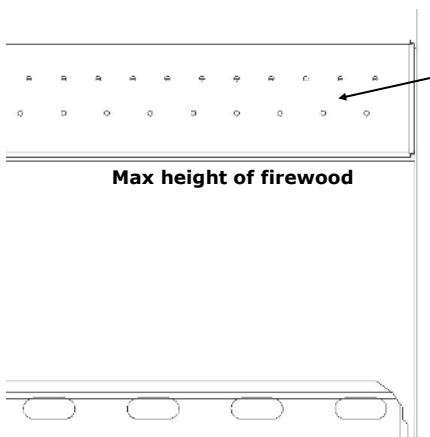

Max height of firewood

Tertiary air

Is constantly added air, which makes the stove burn even cleaner, and lowers the content of tar and soot in the combustion process to an absolute minimum. At optimal combustion settings, glass and combustion chamber will be burnt completely clean, and the remaining amount of ashes will be minimal.

Overheating

Occurs if too much wood is placed in the stove or if the combustion receives too much air.

How it works

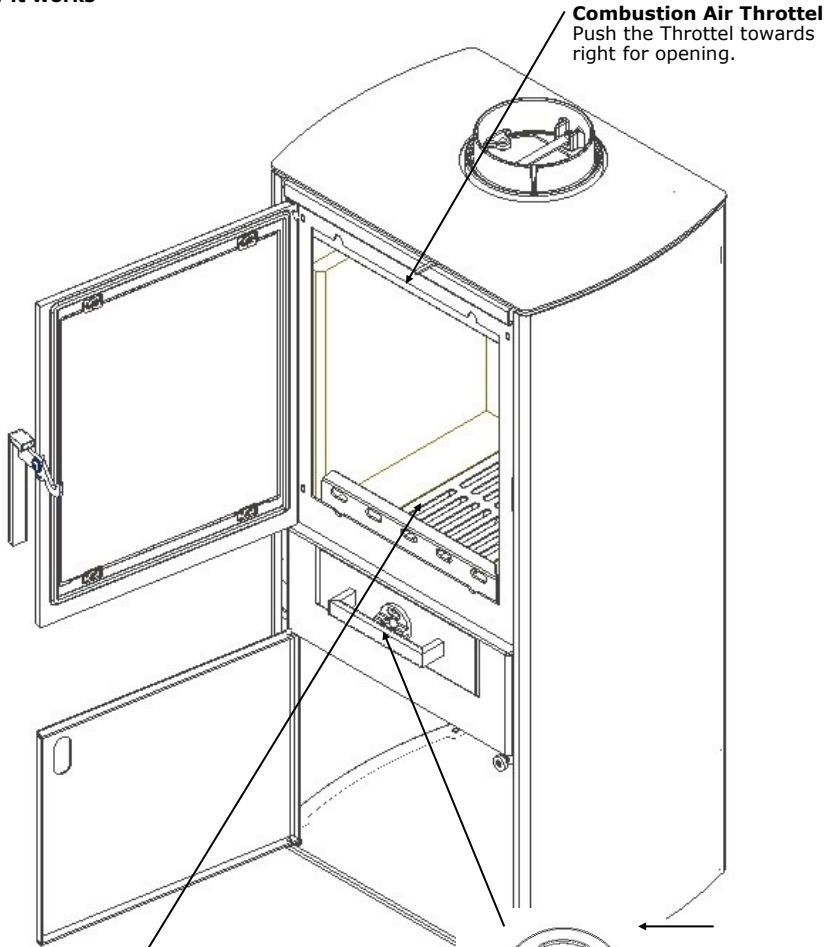

Combustion Air Throttlet
Push the Throttlet towards right for opening.

Bottom grate
The Bottom grate is situated at the bottom of the combustions chamber.

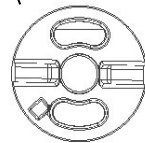

Ignition air
On Ashpan - **Open**

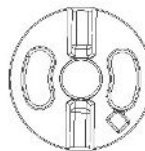

Ignition air
On Ashpan - **Closed**

How to light up and use your stove:

When you use the stove for the first time, the surface coating will cure and smoke will come from the stove and it will have a slightly pungent smell, which will disappear after a good airing. We therefore recommend that you open the doors and windows so there is airflow to/from outside.

During the curing process, the coating will become soft and vulnerable, so therefore avoid touching the coated surfaces. We also recommend that you regularly open and close the door during the first couple of hours to avoid the door's gasket from becoming stuck to the coating.

Never use flammable liquids such as spirits or petrol when you light the fire!

We recommend that you light the fire using the "Top-Down" method, where you light the wood at the top of the combustion chamber rather than at the bottom. This method is the most eco-friendly way to light a fire. At the same time, it will be easier to keep the glass in the door clean.

Cross 2-4 small pieces of kindling on the combustion chamber's base plate (approx. 0.7-1.1 kg). Position them so that there is a small gap between the individual pieces. On top of these, place 8-12 small wooden pins (0.5-0.8 kg), and place 1-2 kindling blocks on the top and in between the wooden pins. In total, about 1.6 kg wood.

It is easier to light the fire if there is a thin layer of ash in the base of the stove.

Before lighting up the stove, open Ignition Air on the ash-pan for access of **primary air**. The Throttle for the Combustion Air is drawn towards the right and hereby fully opens for combustion air.

When the fire burns remember to close the the Ignition air again, or the stove and chimney might become overheated and will invalidate the warranty.

Hereafter the combustion air are adjusted to the need of heat. Be aware not to close too much for the air supply, otherwise the fire will die, the fire must always be bright and clear.

In most instances, however, you will have to achieve the **best combustion air settings** yourself, as the height and draught of your chimney, as well as the quality of the firewood are decisive factors in determining how your particular stove is best set.

If the stove nominal heat output is too large compared to the heat demand, you can reduce the output as described here:

- use a smaller amount of wood than usual, for example. 1.2 to 1.3 kg. and preferably consist-

end of 2-3 smaller pieces of wood. Apply full air to ignite the wood properly, then you can reduce the combustion air, perhaps down to approx. 30%. Be aware not to close too much for the air supply, otherwise the fire will die, the fire must always be bright and clear.

With this method it, (depending on the chimney, wood quality, etc. is possible to reduce the stove heat output from a nominal 5 kW down to 3 - 3.5 kW.

Note that if you reduce the combustion air too much, this can lead to poor combustion, which will result in reduced efficiency and increased emission value in the smoke (increased pollution).

When re-stoking the fire, we recommend that you first open the door and load new wood when there are only embers left inside the combustion chamber. If there are flames, then smoke and gas are still being generated, and depending on the efficiency of your chimney, there is a danger that smoke down draught will enter the room.

When re-stoking, use gloves when **loading** the wood.

Tertiary air

If you are wondering why your stove is fitted with a gap in the rear vermiculite plate in the combustion chamber, with small holes through the back steel plate, where air is running through into the combustion chamber. This is merely a consequence of our newly developed combustion system. We refer to these air ducts as the 'tertiary air', and will prove helpful as you install your new Varde stove.

When refilling the stove with wood, we recommend opening the stove door only once embers are left in the combustion chamber. Opening the door whilst the flames are still burning and producing smoke and gas, might cause smoke to slip into the room instead of up the chimney.

Should you have some issues with the lighting or the function, see section on **troubleshooting**.

Operation

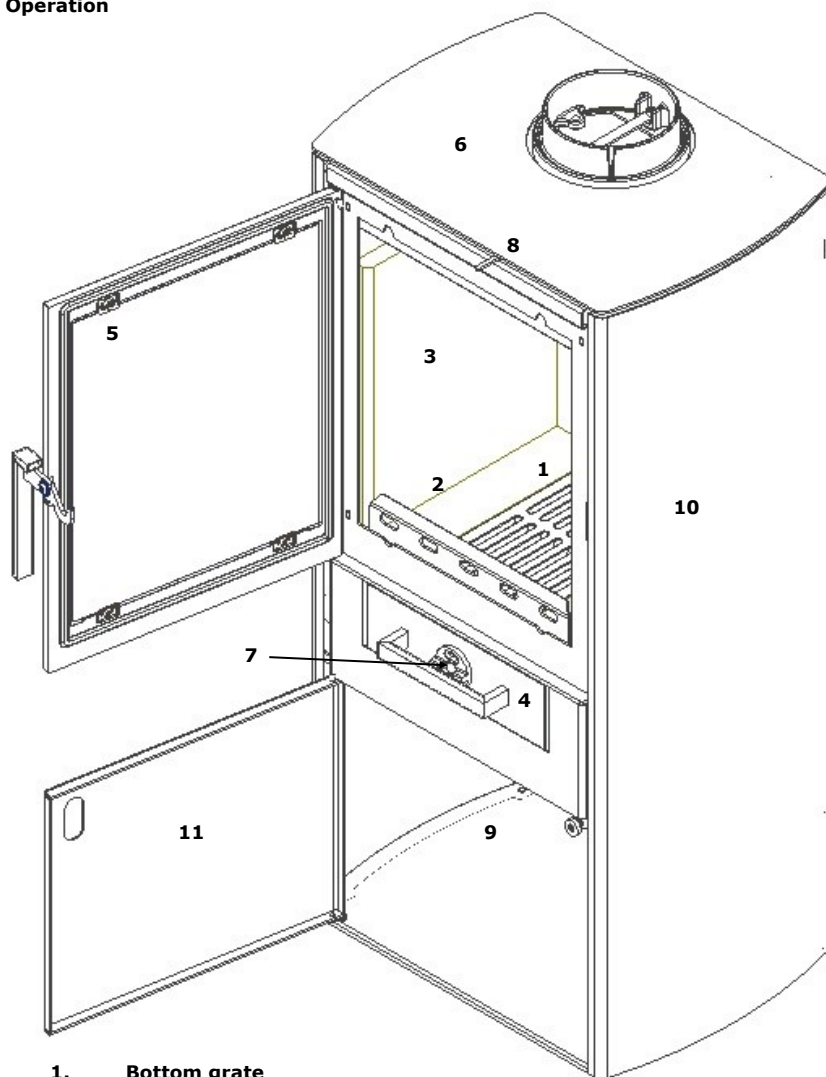

1. Bottom grate
2. Wood catch
3. Vermiculit plates
4. Ash tray
5. Cast iron Door
6. Steel Top
7. Throttlet for Ignition Air
8. Combustion Air Throttlet
9. Storage
10. Site Panels
11. Storage Door (Only on Birkholm, Falster og Tunø)

Vermiculite

The plates in the Combustion Chamber are Vermiculite plates and will eventually be worn, - as will the smoke plate. Should you accidentally break the plate, for instance by hitting it hard with a piece of wood, this does not effect the quality of the combustion. You need not replace the plate until the gap is 5 mm wide.

Vermiculite

A special non-flammable material. The vermiculite fire plates both isolate and protect the stove from attrition. Vermiculite plates and deflector not covered by the warranty. Vermiculite is a very porous material, therefore handle with care. When refilling the stove, put the wood carefully, use the glove.

Only use original parts from Varde Ovne A/S

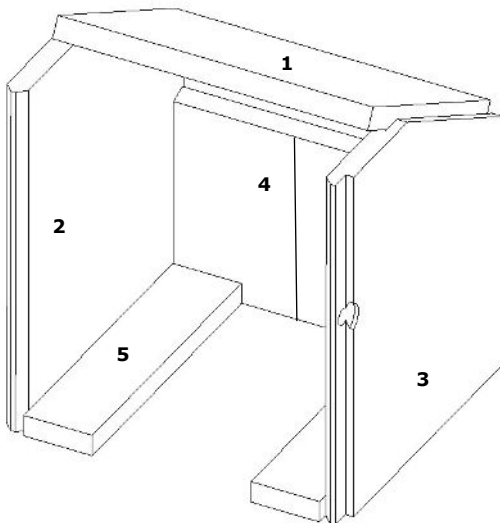

**Vermiculit set,
Item no.: 100661**

- 1. Deflector plate**
- 2. Left side plate**
- 3. Right side plate**
- 4. Rear cover**
- 5. Grate Plates**

How too replace the Vermiculite

1. Remove Grate plates (5)
2. Deflector, lift easily, bottom bag end are tilted forward, take down.
3. The left side plate can be easily liftes up and rotated out.
4. Right side plate can be easily lifted up and rotated out.
5. The Rear cover is liftes up and out of the stove.

Mounting of new Vermiculite plates follow point 5 towards point 1.

What kind of wood to use?

Generally, beech wood is considered the best type of wood for burning. It burns evenly without producing much smoke and ashes are clean and take up little space. Ash, birch and maple wood are fine alternatives.



How big the firewood?

Split firewood with a diameter larger than 10 cm. Use firewood with a length on 20-25 cm. The use of larger quantities of fuel than recommended in the tabel below will overtax the stove and resulte in increased temperatures in the chimney as well as a lowered efficiency. This may cause damage to both chimney and stove, and the annulment of the warranty. Also, never use toxic materials such as chipboard, painted or impregnated wood.

Lightnings sticks

Length: 20 -25 cm
Wide 3x3 cm
Normal amounth: 10-15 sticks (approx. 1,6 kg)

Firewood

Length: 25-30 cm
Diameter: max. 10 cm
Normal amounth: 2-3 firwood (approx. 1,3 kg)

The new stove

When you use the stove for the first time, the surface coating will cure and smoke will come from the stove and it will have a slightly pungent smell, which will disappear after a good airing. We therefore recommend that you open doors and windows so there is airflow to/from outside. During the curing process, the coating will become soft and vulnerable, so therefore avoid touching the coated surfaces. We also recommend that you regularly open and close the door during the first couple of hours to avoid the door's gasket from becoming stuck to the coating.

What to burn.

This Varde Stove is tested and approved for the burning of wood. Only dry wood with a moisture content of maximum 21 percent and the size to fit into the combustion chamber should be used. The burning of moist wood will result in an increased amount of tarry soot, pollution and uneconomic fuel consumption. Newly chopped wood contains about 60-70 percent moisture, which makes it completely unsuitable as fuel. Allow newly chooped firewood to dry in a open shed for a couple of years before using it in the stove.

Do not use! - Consider the environment

Also, never use toxic materials such as chipboard, painted or impregnated wood.

The use of larger quantities of fuel than recommended in the tabel below will overtax the stove and resulte in increased temperatures in the chimney as well as a lowered efficiency. This may cause damage to both chimney and stove, and the annulment of the warranty.

Topdown Lightning of the fire

Please do not load more than shown on page 14.



The following optimal register and fuel quantity settings are recommended(in case of similar chimney draught):

Fuel Quantity [kg]	Primary Air open [%]	Combustion Air open [%]	Nominal Output [kW]	Chimney Draught [PA]	Efficiency [≥ i %]	Refill interval at nominal output [minuts]
1,2	0 (closed)	ca. 60 (almost open)	5,0	12	81	ca. 45

Maintenance:

As with anything else that you use on a daily basis, your stove must of course be maintained. You should only clean your stove when it is cold. Wipe the outside using a dry cloth, do not use water or cleaning detergents, it will wear out the heat resistant paint on the stove very fast. You should as well clean it regularly on the inside. The actual combustion chamber should be cleaned of ash and soot remnants. You should also remove the smoke guide plate, because dirt and soot will build up behind it, and check that there is free access through the flue and chimney. You should also check that the gaskets in the door and ash pan are not worn out. If the gaskets do not seal properly, they must be replaced. Remember to lubricate the door hinges as required.

Glass

We recommend the use of VARDE glass cleaner to clean the pane; this can be bought from our dealers.

The **ash pan** must be emptied regularly, and the ash can be disposed of along with your domestic waste. But you must of course make sure that the ash does not contain any embers. If you are unsure about how to clean or maintain your wood-burning stove, contact the dealer who sold you the unit or contact your chimney inspector.

In particular, following a long period of time where you have not used the stove, before using it again you must make sure that there is nothing blocking the flue or the chimney.

Some exposed areas of the **stove's painted surface** can over time become worn out e.g. through cleaning or overheating of the wood-burning stove. However, this can be repaired using a special coating, Senotherm®, which comes in a spray can and can be purchased from your dealer.

The **panels in the combustion chamber** are known as **vermiculite panels** and will become worn over time. If a piece of wood damages a vermiculite panel, it has no effect on combustion. You do not need to replace the panels unless the crack in the panel is more than about ½ cm wide.

Only original spare parts from Varde Ovne A/S may be used.

The door is fitted on a lock spring, which pulls the door in. This is a regulatory requirement in certain countries. The spring is attached to the hinge, and can be removed if you do not wish to have a spring-loaded door.

No unauthorised alterations may be made to the wood-burning stove.

All of the exterior parts of the wood-burning stove will become very hot during use. You should therefore exercise necessary caution.

IMPORTANT!! Chimney fires

If your chimney catches fire, you must follow this procedure:

- Close all of the air supplies to the stove and telephone **112**.

(Most chimney fires will go out on their own once you have stopped any air from getting into the stove).

As a minimum, you must contact your chimney inspector, who will then inspect the stove and chimney for damage.

Troubleshooting.

Smoke enters the room:

- Not enough draught in the chimney.
- Inspect the smoke pipe or the chimney for blockage.
- Clean the inside of the stove removing soot from the upper vermiculite / smoke (Deflector) plate.
- Make sure the height of the chimney is correct.

The glass or the chimney soot up:

- The wood is too moist.
- Not enough secondary air is applied to the combustion process.
- You may have shut off the supply of ignition air too early when lighting up the stove.
- There always have to be clear flames in the combustion chamber.

The heat is emitted from the stove:

- The wood is too moist (all energy goes into drying it) or of a poor quality.
- Inspect the position of the smoke plate and make sure there is free passage for the smoke.
- The amount of combustion(secondary air) air is not enough.

Combustion is too intense:

- Gaskets in the door or the ash-pan are no longer tight and need replacement.
- The chimney draught is too strong—apply a valve in the chimney.
- Inspect that the ignition air is closed.

The Shake grate is stuck:

- Inspect the grate for jammed wood, nails or the like.
- Make sure the lever is placed correctly.

Recycling

Packing

The packing is 100% recyclable.



Ceramic Glass

Ceramic glass to be deposited at the local recycling center and sorted together with pottery and porcelain.

Vermiculite

Vermiculite plates from the stove must be returned to the local recycling center.

Spare Parts

If Spare parts at any time should be needed, please check the list below.

Log retainer, Artikel nr.: 100366

Top Cover steel Ø165 VO-Logo, Artikel nr.: 100701

Door Complete Cast Iron Artikel nr.: 100577

Glass, Artikel nr.: 100272

Handle Complete, Artikel nr.: 100363

Ashpan Complete Black, Artikel nr.: 100364

Vermiculite Set, Artikel nr.: 100661

**Gasket for glass and ash pan, product number and EAN number 100443 /
5703505045457**

**Gasket for door incl. glue, product number and EAN number: 100351 /
5703505040162**

Glass cleaner spray, product number and EAN number: 100493 / 5703505045471

Repair spray for paint

Black 400 ml: 100603 / 5701909002069

Grey 400 ml : 100604 / 5701909006142

PRØVNINGSATTEST

Rhein-Ruhr Feuerstätten Prüfstelle • Im Lipperfeld 34 b • 46047 Oberhausen

- ❖ Anerkendt prøveinstitut i h. t. Delstatsbyggevedtægterne, reg.nr.: NRW 15
- ❖ Anerkendt prøveinstitut for byggetilsynsmæssige tilladelser
- ❖ Anerkendt DIN CERTCO prøveinstitut, reg.nr.: PL139
- ❖ Anerkendt prøveinstitut, godkendt af Europakommissionen, notified body: 1625



Rhein-Ruhr Feuerstätten Prüfstelle



Kontrolerklæring nr. RRF – DK 17 4482

Provens art	Prøve i h. t. DIN EN 13240		
Genstand for prøven:	Brændeovn Als, Birkholm, Falster, Lolland, Tuno		
Ordregiver:	Varde Ovne A/S , Soldalen 12, DK – 7100 Vejle		
Nominal varmeydelse:	5,0 kW		
Støvemissionen:	14 mg/m ³ _n ved 13% O ₂ efter CEN/TS15883, Annex A. 1 (DINplus metode)		
OGC	80 mg/m ³ _n ved 13 % O ₂ efter CEN/TS15883, Kapitel 4		
Virkningsgrad:	81 %		
CVR nr.:	21554979	P-nr.:	1005018532

Prøvningsresultater: CO-volumenprocenten i forbrændingsgassen i ovennævnte brændeovn udgør ved en nominal varmeydelse ifølge prøvebetingelserne i DIN EN 13240 med prøvebrændslet brændestykker 0,09 vol.-%, (1125 mg/m³_n) relateret til 13 % O₂.

Bemærk venligst, at de oplyste værdier er uddrag af prøvningsrapporten.

Det attesteres herved at ovenfor nævnte fyringsanlæg opfylder emissionskravene i: Bilag 1 til bekendtgørelse nr. 46 af 22/01/2015 vedr. regulering af luftforurening fra fyringsanlæg til fast brændsel under 1 MW (1. og 2. trin).

Godkendelsesafdelingens leder

Dipl.-Ing. S. Müller
Oberhausen, 17.02.2017

Skorsensfejer påtegning

Dato, underskrift

PRØVNINGSATTEST

Rhein-Ruhr Feuerstätten Prüfstelle • Im Lipperfeld 34 b • 46047 Oberhausen

- ❖ Anerkendt prøveinstitut i h. t. Deistatsbyggevedtægterne, reg.nr.: NRW 15
- ❖ Anerkendt prøveinstitut for byggetilsynsmæssige tilladelser
- ❖ Anerkendt DIN CERTCO prøveinstitut, reg.nr.: PL 139
- ❖ Anerkendt prøveinstitut, godkendt af Europakommissionen, notified body: 1625



Rhein-Ruhr Feuerstätten Prüfstelle



Deutsche
Akkreditierungsstelle
D-PL-17727-01-00

Kontrollerklæring nr. RRF – 40 14 3654

Prøvens art	Prøve i h. t. DIN EN 13240	
Genstand for prøven:	Brændeovn Samsø	
Ordregiver:	Varde Ovne A/S, Soldalen 12, DK – 7100 Vejle	
Nominal varmeydelse:	5,0 kW	
Støvemissionen:	14 mg/m ³ _n ved 13% O ₂ efter CEN/TS15883, Annex A. 1 (DINplus metode)	
OGC	80 mg/m ³ _n ved 13 % O ₂ efter CEN/TS15883, Kapitel 4	
Virkningsgrad:	81 %	
CVR nr.:	21554979	P-nr.: 1005018532

Prøvningsresultater: CO-volumenprocenten i forbrændingsgassen i ovennævnte brændeovn udgør ved en nominal varmeydelse ifølge prøvebetingelserne i DIN EN 13240 med prøvebrændslet brændestykker 0,09 vol.-%, (1125 mg/m³_n) relateret til 13 % O₂.

Bemærk venligst, at de oplyste værdier er uddrag af prøvningsrapporten.

Det attesteres herved at ovenfor nævnte fyringsanlæg opfylder emissionskravene i: Bilag 1 til bekendtgørelse nr. 46 af 22/01/2015 vedr. regulering af luftforurening fra fyringsanlæg til fast brændsel under 1 MW (1. og 2. trin).

Godkendelsesafdelingens leder

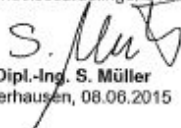
Dipl.-Ing. S. Müller
Oberhausen, 08.08.2015

Skoisensfejer påtegning

Dato, underskrift

Warranty

All **Varde stoves** undergo substantial quality control, and we take pride in supplying the same high quality at all times. We do, however, offer a **5-year warranty** for any manufacturing defects, should they occur.

The warranty does not cover:

- Wearing parts, vermiculite panels in the combustion chamber, glass, handles, gaskets, cast-iron base and shaker grate.
- Damage there is the result of incorrect operation, e.g. overheating, unapproved fuel, incorrect connections, lack of or incorrect maintenance, etc. (see these user instructions).
- Damage caused by external effects of a physical nature.
- Transportation costs in connection with any warranty repair.
- Installation/dismantling during the warranty period.
- Compensation for any consequential damage, including damage to other items.

All enquiries regarding complaints must be made through the dealer where the stove was purchased.

When making a complaint, make sure that the complaint includes pictures, the purchase receipt and the 16-figure serial number, which is on the rear of the stove.